

Rückansicht

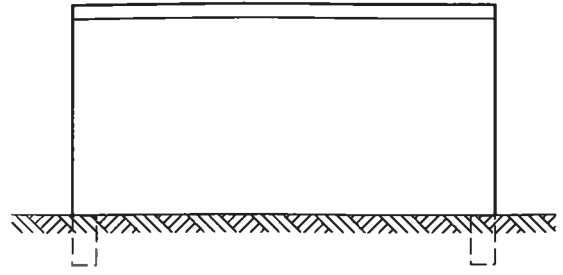

Seitenansicht

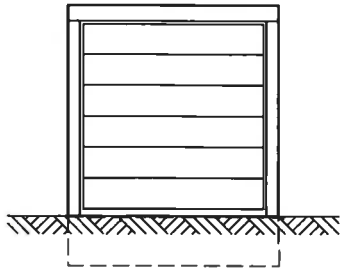

Vorderansicht

OK Garage
+3,48

UK Garage
±0,00

-0,02
OK Fundament

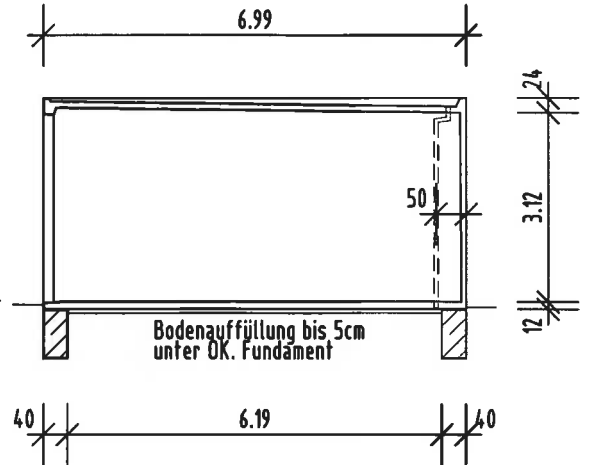

Längsschnitt

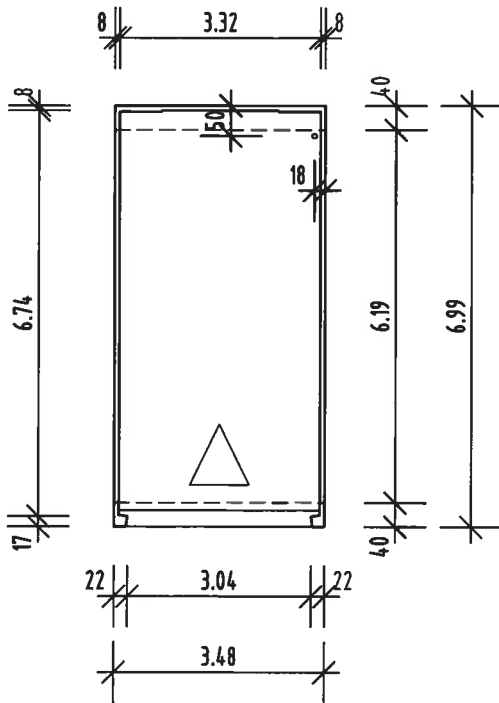

Grundriss

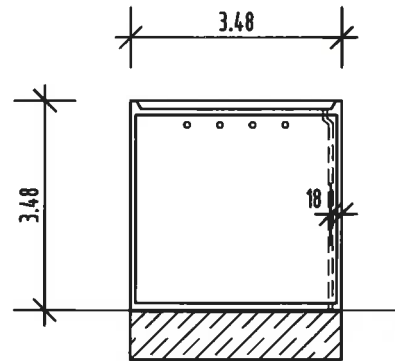

Querschnitt

Rekers RF 770 D

Nutzfläche: $3,32 \times 6,74 = 22,38 \text{ qm}$

Bebaute Fläche: $3,48 \times 6,99 = 24,33 \text{ qm}$

Umbauter Raum: $3,48 \times 6,99 \times 3,48 = 84,65 \text{ cbm}$

(Datum, Entwurfsverfasser)

M = 1 : 125

RF 770 D		REKERS				BETONWERK GmbH & CO.KG	
BAUHERR	Amprion GmbH Rheinlanddamm 24 44139 Dortmund	Werk Spelle	Werk Gelsenkirchen	Werk Groß-Ammenleben	Werk Ochenbruck		
BAUORT	Kabelübergabestation Klusebrink, Borgholzhausen	Portlandstr. 15 48480 Spelle TEL(0 59 77) 71-0	Im Busche 62 45886 Gelsenkirchen TEL(02 09) 1 79 99-0	Langer Schlag 1 39326 Groß-Ammenleben TEL(039 202) 86-0	Industriestr. 1 90592 Ochenbruck TEL(09128) 7244-0		